

MAGNET HEAT PUMPS

ENERGY EFFICIENT HOT WATER SYSTEMS



70% Electricity Saving

www.magnetgroup.co.za

DBN 031 274 1050

RBAY 035 797 4866

CT 021 532 5360

JHB 011 397 7936

Magnet
AHEAD OF CURRENT THINKING

Magnet Heat Pumps Energy Efficient Hot Water Systems



Energy Efficient Hot Water Heating

Heat Pump Water Heating is a new technology in the domestic market and is viewed as the latest generation of water heating systems. It surpasses coal, electric, gas and even **solar** water heating, offering a better solution for energy saving and environmental protection.

Easy Installation

Can be mounted outside on wall brackets (similar to a split unit air conditioner) or in roof space next to the existing geyser, if there is adequate space. Connects to your existing geyser and replaces the electrical element as the heating source. The element is left in place for back up and redundancy purposes but the power is isolated. This can be switched back on by simply flicking a switch if the heat pump is down for maintenance or you have extra guests which will **halve the heat up time**.

Safety

No risk of bursting geysers and flooding of ceiling's, due to faulty thermostats. Water and the electricity are completely isolated. No risk of electric shock while using water.

Energy and Costing saving's

Save thousands of Rands every year on the cost of running your existing Geyser Element. Help you save up to 70% of the water heating costs that you spend on your conventional water heaters. Maintenance costs are also very low.

All-weather running

Unlike Solar. Heat Pumps deliver reliable hot water day and night under all types of weather conditions, including rain and snow.

Will operate in temperatures from (-7°C to 43°C)

Environmental protection

Huge saving benefits to the environment by reducing CO² emissions. Do your bit to help reduce **Global Warming**

Domestic Split Cycle-Heating Type



MHP-28/C—72/C

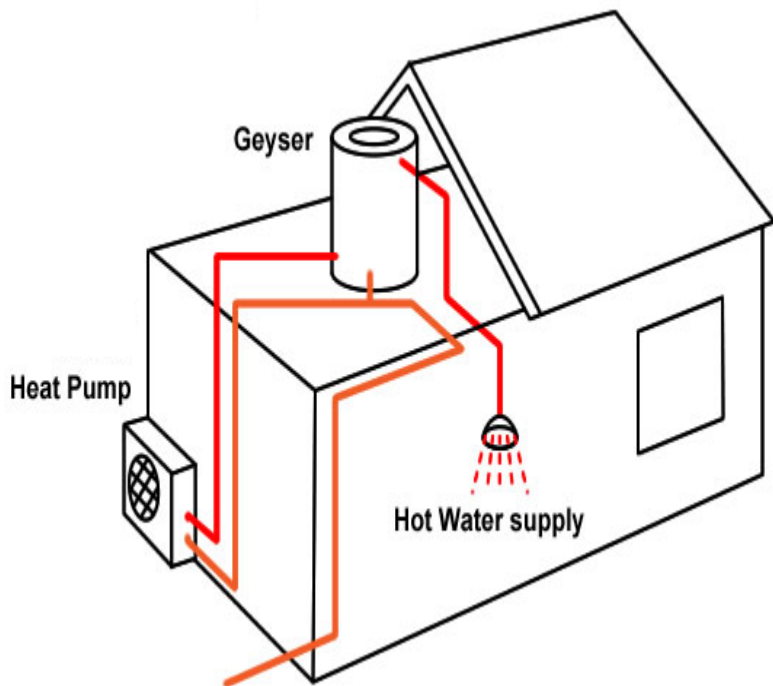

SPECIFICATION

Model		MHP-28/C	MHP-35/C	MHP-50/C	MHP-72/C	MHP-65/C
Heating Capacity	kW	2.8	3.5	5.0	7.2	6.5
Rated Power Input	kW	0.81	0.9	1.1	1.9	2.02
Hot Water Flow	m ³ /h	0.06	0.08	0.11	0.16	0.15
Max Power Input	kW	1.14	1.2	1.6	2.7	2.7
Power Supply	V-ph-Hz	220-1-5-				220-240-1-50
Water Outlet Temperature	°C	55°C Default, adjustable (40°C - 55°C)				
Size Water Inlet pipe	mm	DN15	DN15	DN15	DN15	DN15
Size Water Outlet Pipe	mm	DN15	DN15	DN15	DN15	DN15
Size Water Circulation Pipe	mm	DN20	DN20	DN20	DN20	DN20
Water tank capacity	L	100-180	100-180	180-250	200-300	200-320
Net Dimensions (W-H-D)	mm	790x736x260	790x736x260	790x736x260	840x904x314	845x940x314
Packing Dimensions (W-H-D)	mm	905x807x355	905x807x355	905x807x355	965x1009x395	965x1009x395
Net Weight	kg	47	50	56	75	81
Gross Weight	kg	51	53	59	80	86.5
Noise Level	dB	49	49	52	57	52

Structure View

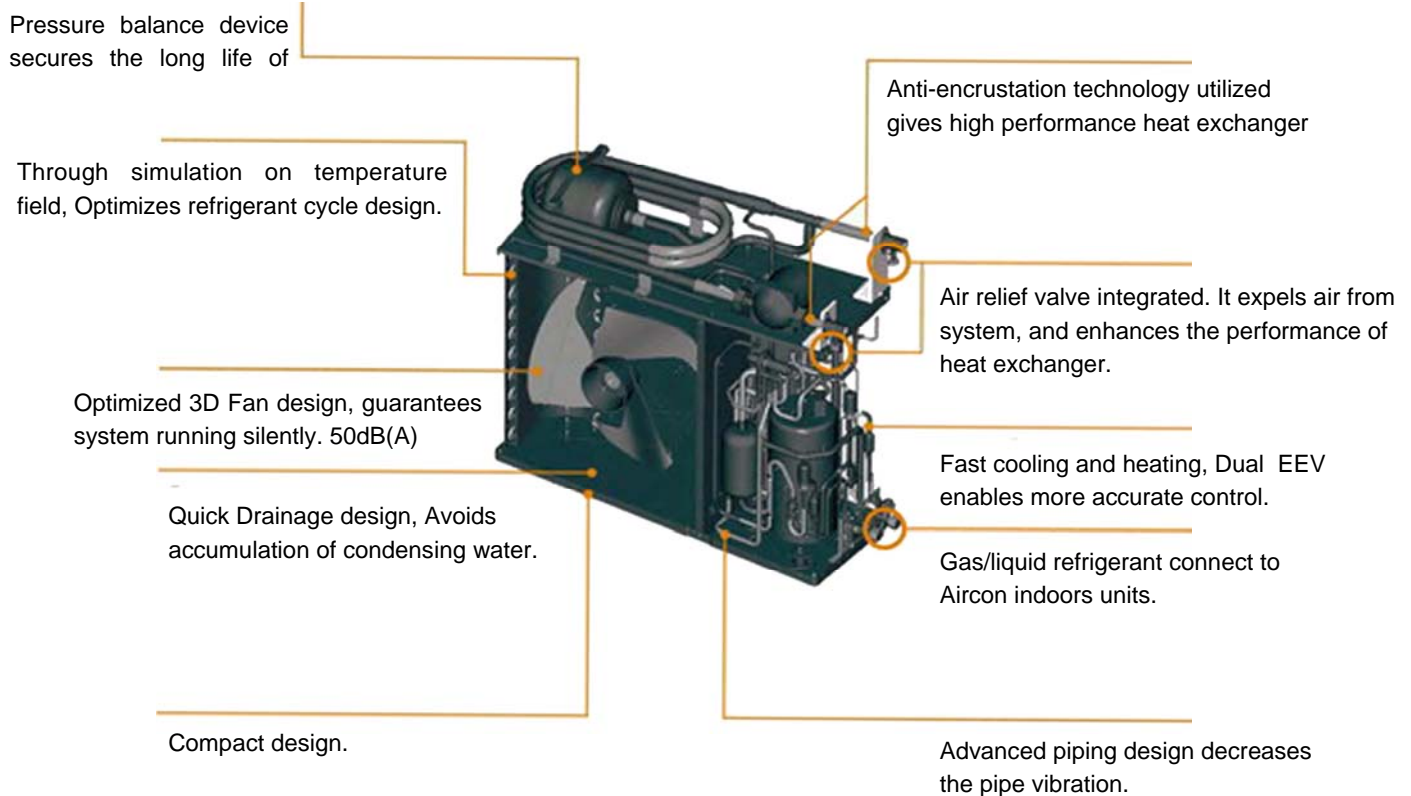

Coefficients of Performance

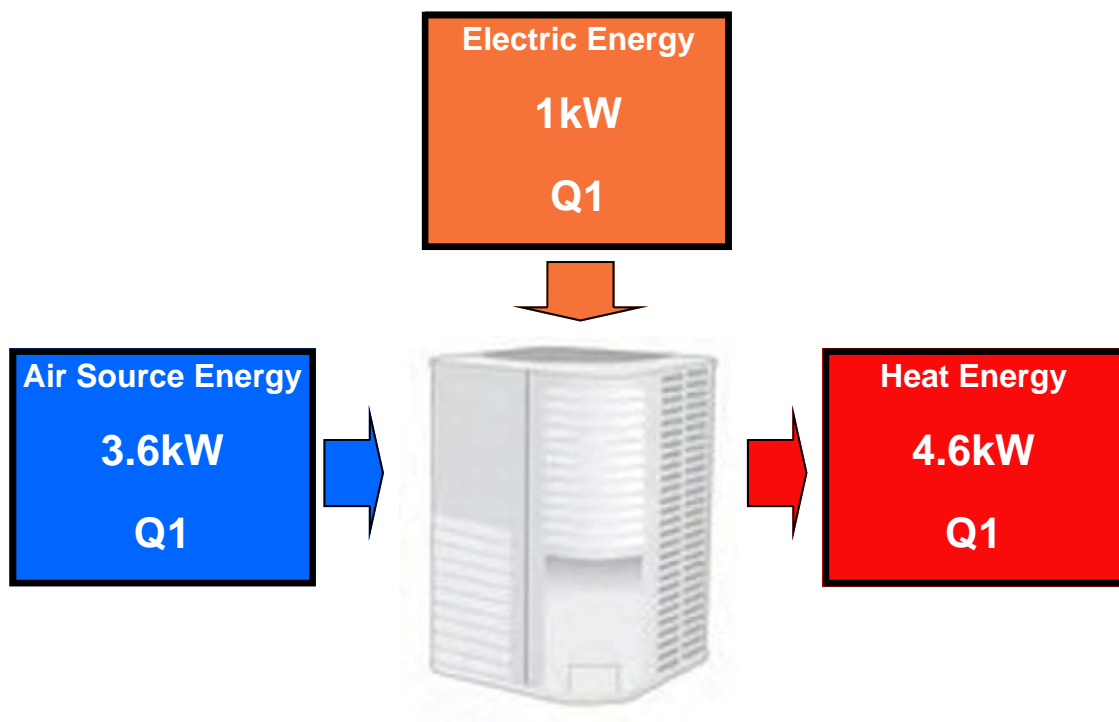

Benefits

- **Safety**

No risk of bursting geysers and flooding of ceiling's, due to faulty thermostats. Water and the electricity are completely isolated. No risk of electric shock while using water.

- **High efficiency**

Applying heat pump principle and producing hot water with energy absorbed from environment. The efficiency can be up to 450%.

- **All season running**

Within the temperature range from -7°C to 43°C , which means it can work not just in sunny days, but night, heavy cloudy, rainy and snowy day.

- **Full automatic control, easy to use**

- **Reduction in CO² to atmosphere and environment**

- **Environment-friendly.**



Conception of Water Heating

Air Source Heat Pump Water Heater, represents the latest water heating technology, and works on the principle of a reversed refrigerant cycle, drawing heat out of atmosphere (air) and discharging it into the water.

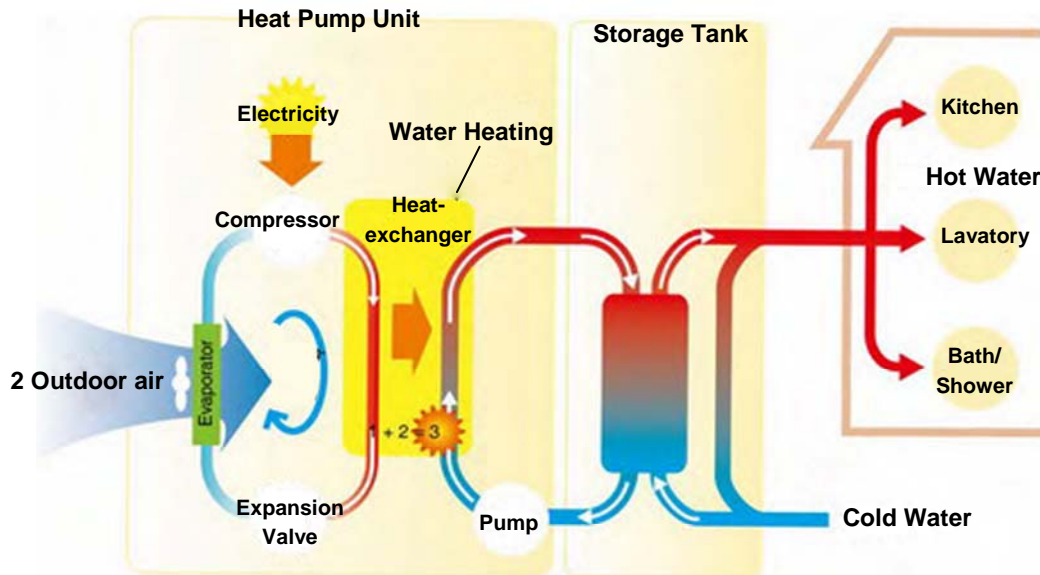

Consumption Comparison

Power consumption comparison under the same condition to heat 1 ton water from 15°C to 55°C

	Magnet HWHP	Gas Water Heater	Electric Water Heater	Boiler	Solar Water Heater
Energy Resource	Air, Electricity	Gas	Electricity	Diesel Oil	Solar, Electricity
Transfer Factor	860kcal/kW.h	24000kcal/kW.h	860kcal/kW.h	10200kcal/kW.h	860kcal/kW.h
Average Efficiency	3.5	0.8	0.95	0.7	2.7 (1/3 weather need Auxiliary Heater)
Consumption	10kW.h	2.08m ³	48.9kW.h	5.6kg	17.5kW.h
Running Cost (R)	9.73	45.61	35.74	50.25	12.83
Merit/Demerit	<ul style="list-style-type: none"> - Green - Safe - Energy Saving - Environmentally Friendly - Easy for Installation 	<ul style="list-style-type: none"> - Risk potential - Danger of fire and explosion - Cause CO² Emission etc. 	<ul style="list-style-type: none"> - Risk - Electric shock - Emission etc. 	<ul style="list-style-type: none"> - Risk potential - Danger of oil leakage, fire and explosion - Cause CO² etc. 	<ul style="list-style-type: none"> - Not easy for installation - Large area will be occupied - Effective water tank volume is limited.

Intelligent Wired Controller

- Auto mode: It automatically sends on/off signal to master unit, and the unit will start.
- Manual mode: under “Manual mode”, water heating will increase to the setting temperature, and then return to “Auto mode”.
- Timing Function.
- Water outlet temperature is adjustable.
- Auto restart function.
- Monitor and display the running status of the system, when abnormalities happen, malfunction or protection code will be indicated on the screen.

Controller

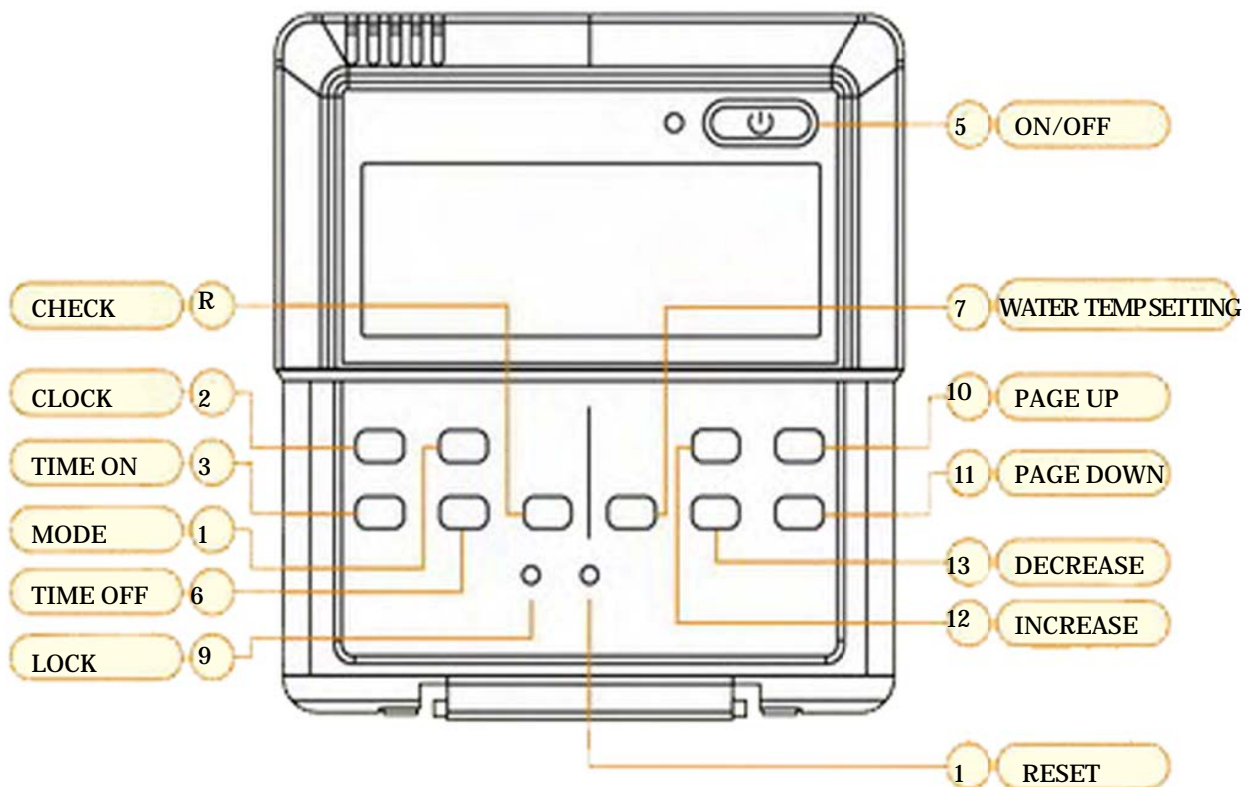

References

Luxury home in Zinkwazi (North Coast of KZN)



2 x 2.8 kW Heat Pump supplying
2 x 200Litre solar Therm Geysers

Home on the beach in Ballito KZN



1 x 7.2 kW Heat Pump feeding
a 600Litre Industrial Geyser

Champagne Sport Resorts (Hotel Complex in KZN Drakensburg)



1 x 20 kW heat pump supplying a
2300Litre Industrial Boiler

DURBAN

Head Office

48 Hannah Rd

Congella

Durban

Tel: 031 274 1050

Fax: 031 205 4602

RICHARDS BAY

Tel: 035 797 4866

Fax: 035 797 4865

CAPE TOWN

Tel: 021 532 5360

Fax: 021 531 0575

JOHANNESBURG

Tel: 011 397 7936

Fax: 011 397 8081

www.magnetgroup.co.za

